

COLORFUL ROOFING TILES ROLL FORMING MACHINE

For Pre Painted Galvanized Tile Roofing Sheets



鐵板厚度 SHEET THICKNESS	0.3~0.7mm
成型速度 FORMING SPEED	18~20下 PER MINUTE
輪模軸徑 ROLLER SHAFT DIA	φ75mm
輪模組數 ROLLER STATIONS	18~24
動力馬達 MOTOR OUTPUT	15~30hp
全長X全寬 LENGTH X WIDTH	L 8~12M W 1.4~1.8M
單頭放料架載重 SINGLE HEAD UNCOILER	5~8Ton

LIKEST

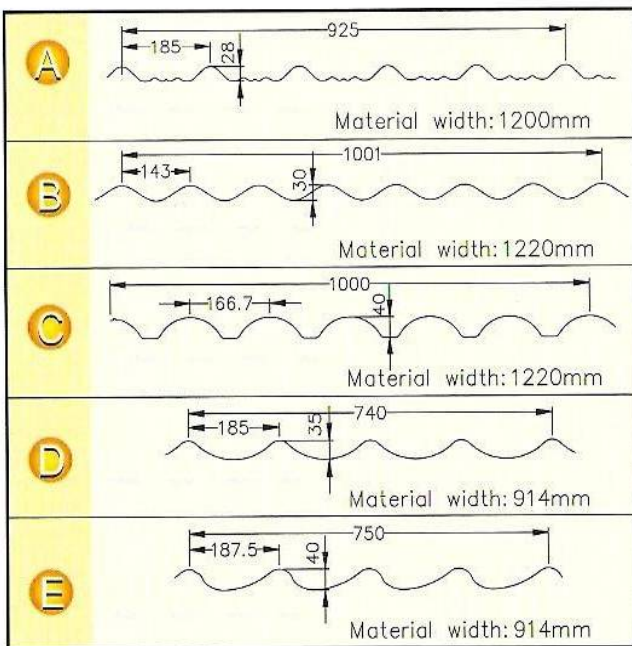

www.likest.com LIKEST, LIKE the best
www.punching-machine.com

Ball Slide Rail Roll Forming Machine (滑軌輥輪成型機)

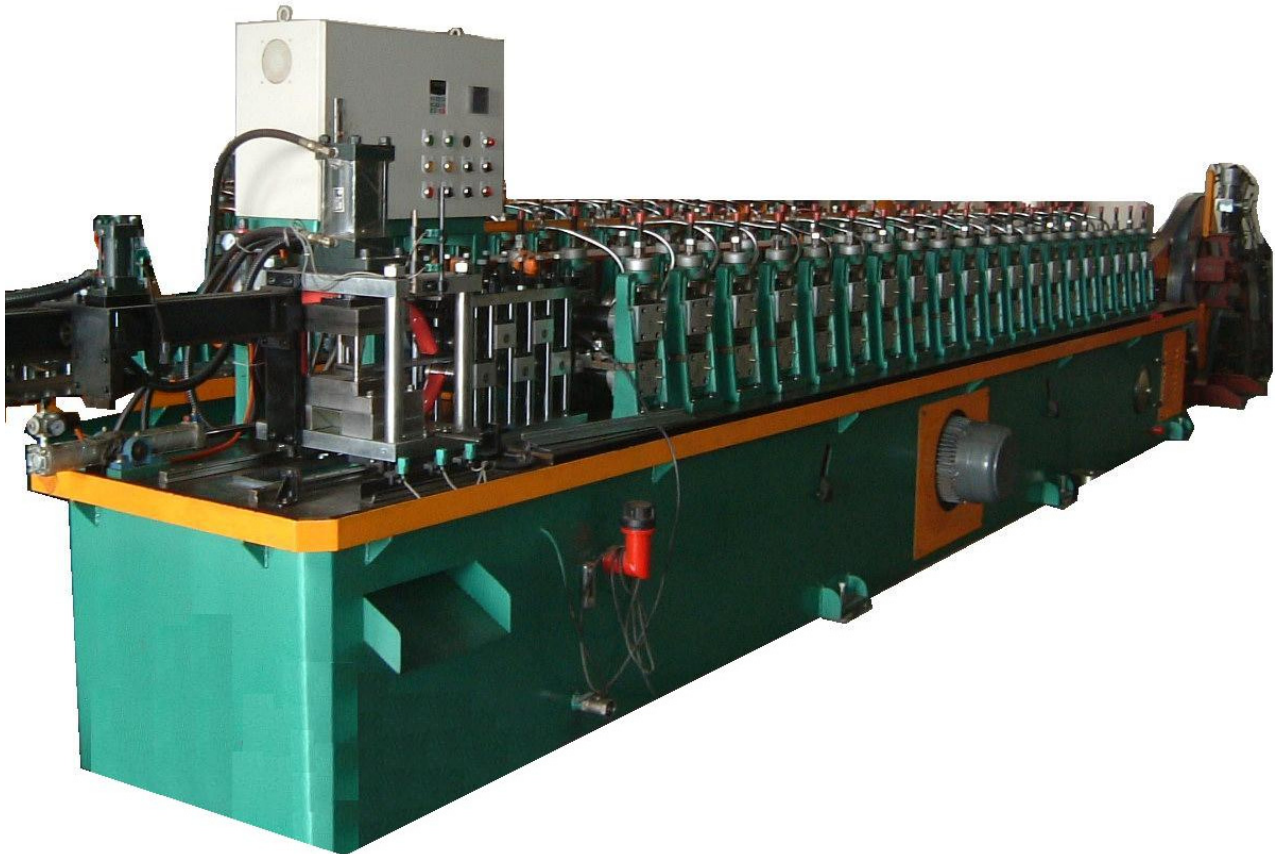

成品材質 Material	製造速度 Forming Speed	生產數量 Production Capacity
SGC400	9m/min~18m/min	25~35 pcs/minute, base on the 300 mm length product.

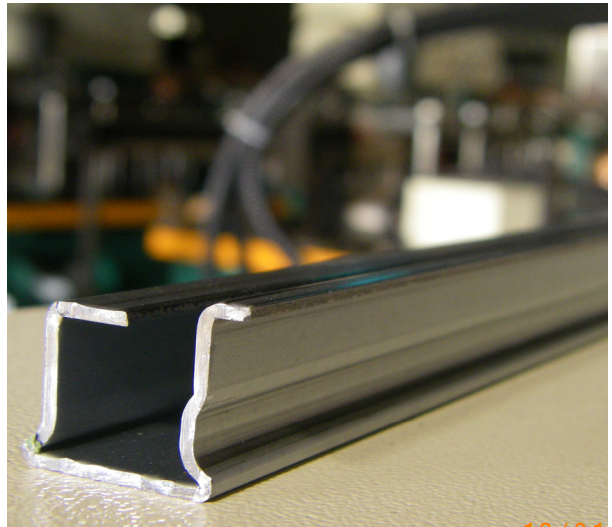
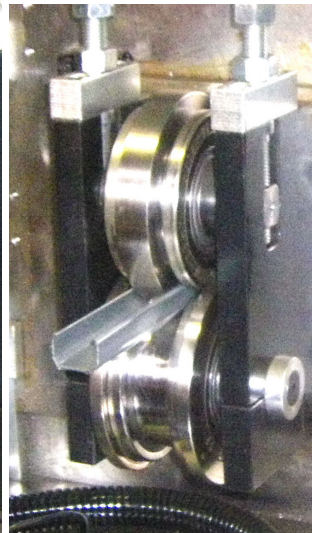
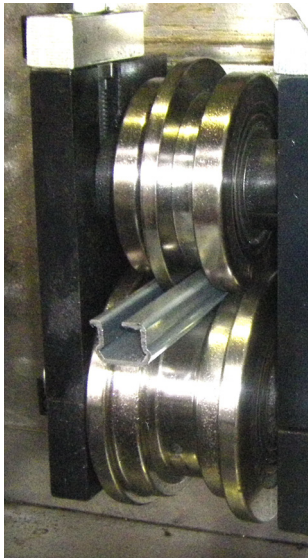
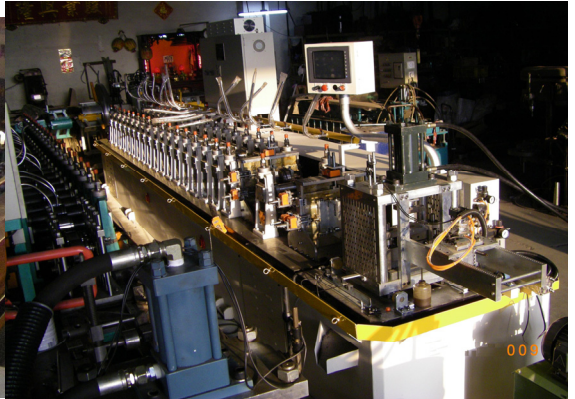
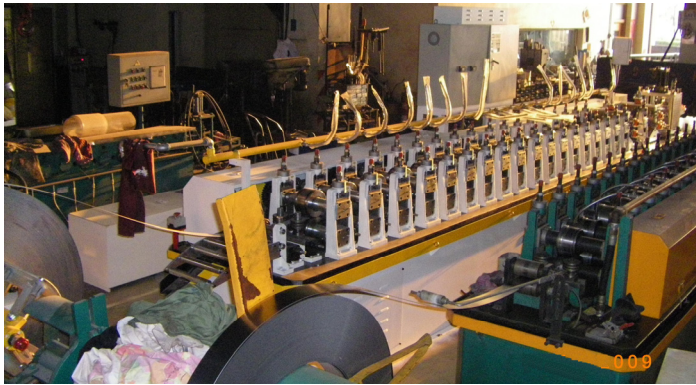

Roller Changeable / Exchange Platform Base (交換台式滑軌成型機)

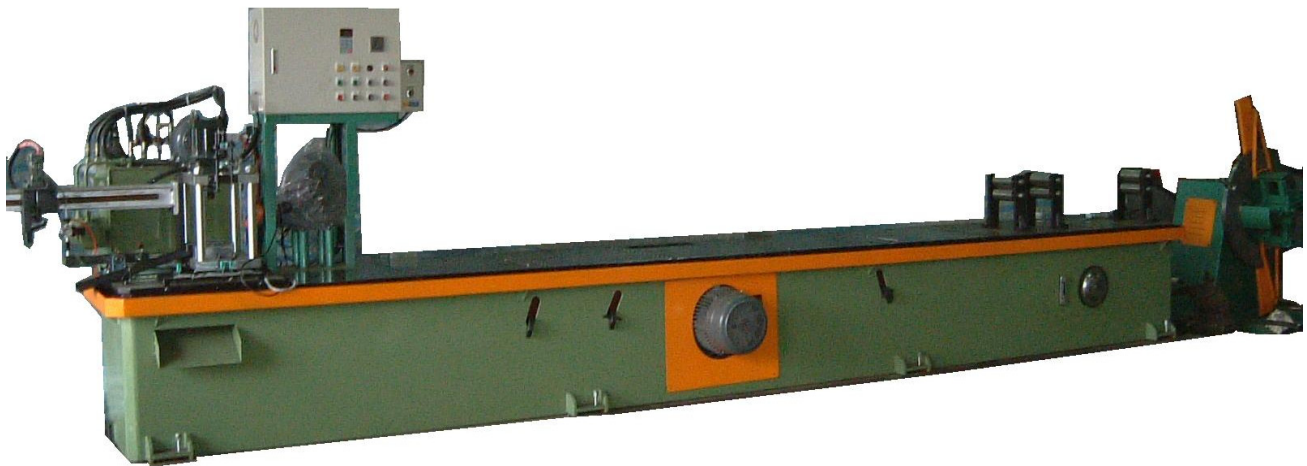
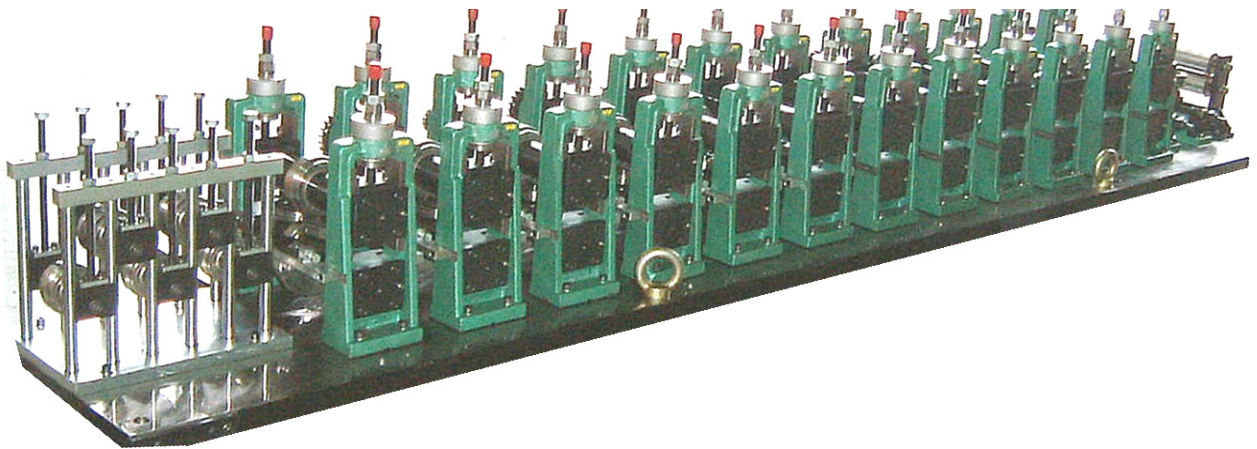
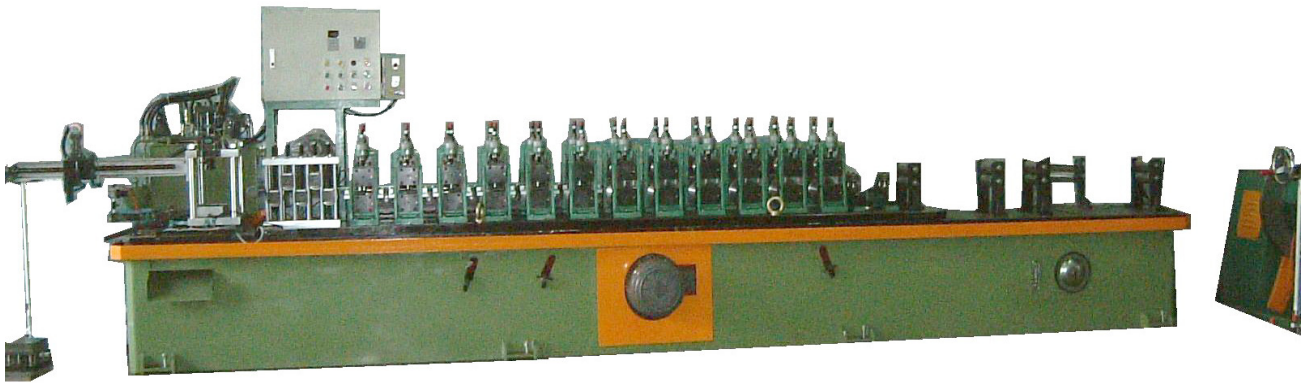

優點：一個產品生產完成，要換另一個產品生產時，可以快速換另一產品生產，不用重新更換輥輪模具及架模。如以更換模具來調試模具未必可以一次完成，調機過程很容易有問題（如產品尺寸有誤差或平行度、整直度不平直時，調機時間就會較久）這樣就較浪費時間，且架模方面也須要有相當的技術人員去調機，假如用交換台式成型機，較不會有這些問題，可以快速換另一產品生產，時間性將會節省很多，也較沒有調機廢料。

Ball Slide Rail Finished Product (滑軌產品)

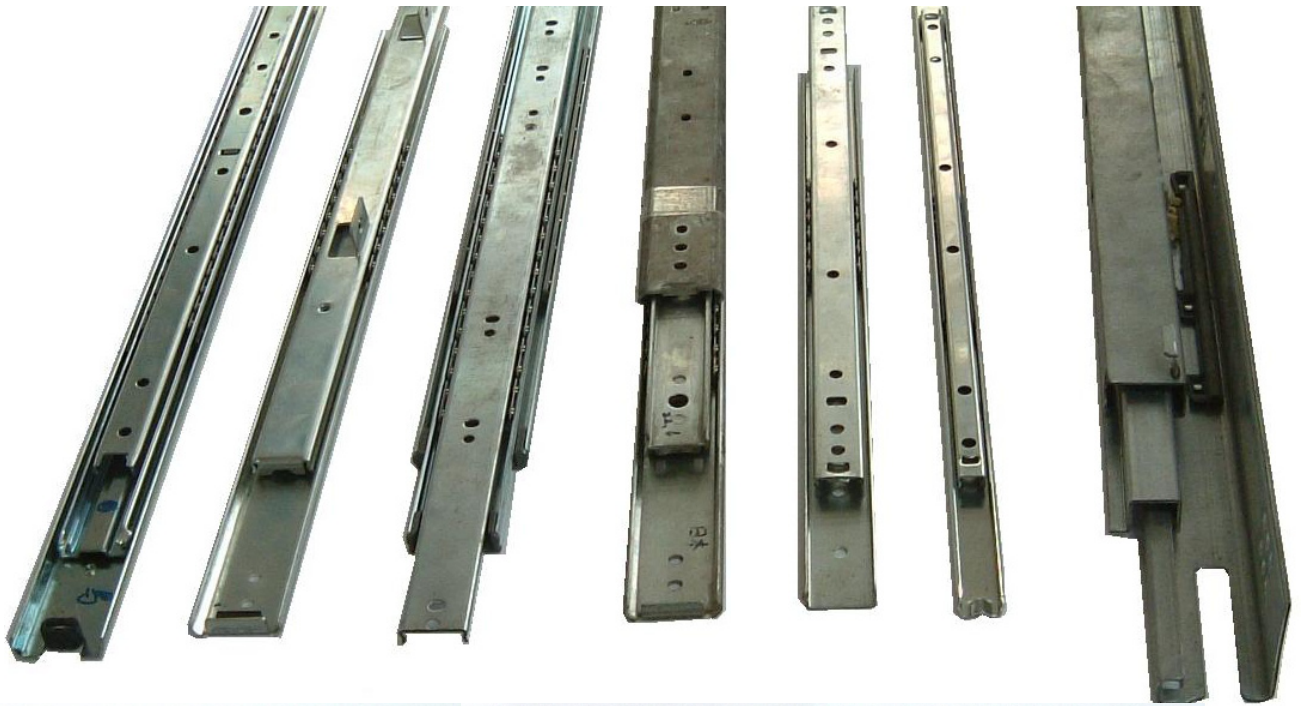

PU SANDWICH PANEL LINE

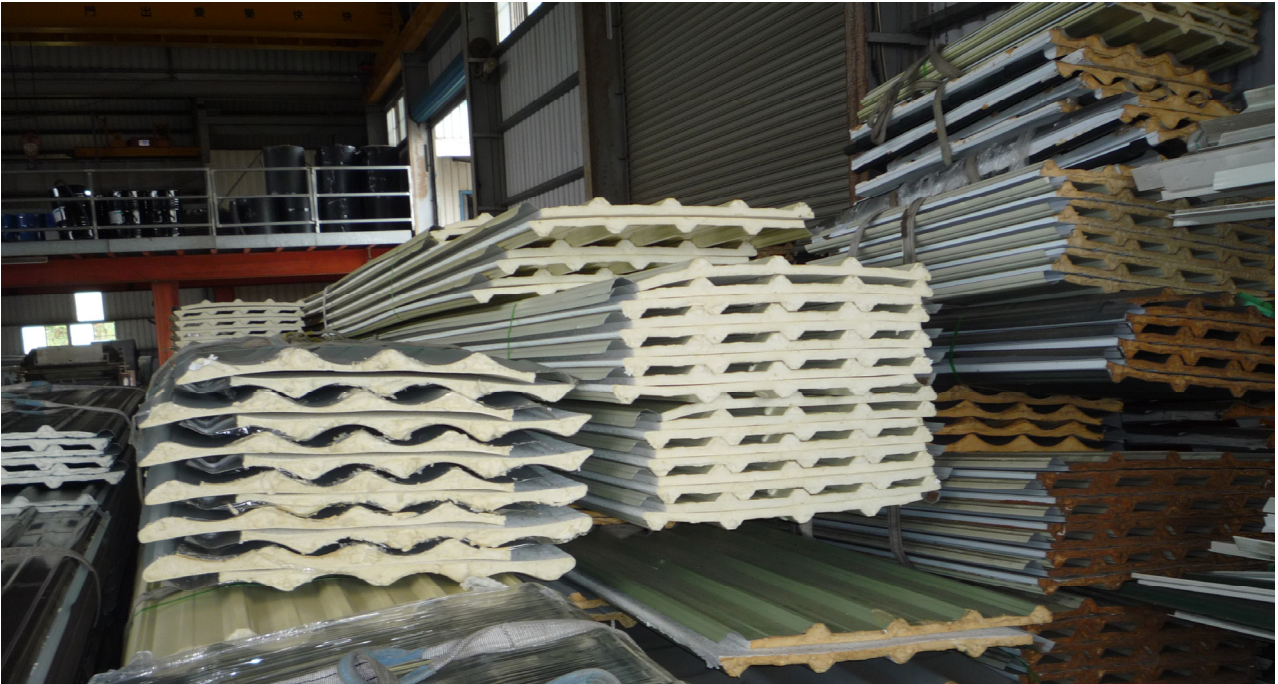

SINGLE SKIN SANDWICH ROOF PANELS PRODUCTION LINE for Single Skin Rigid Polyurethanes Foam (RPUF) Roof Panels



DOUBLESKIN SANDWICH ROOF PANELS PRODUCTION LINE for Rigid Polyurethanes Foam (RPUF) Roof Panels and DOUBLE SKIN SANDWICH WALL PANELS



POLYETHYLENE SANDWICH PANELS PRODUCTION LINE

FLOOR DECKING PANELS (STEP FLOOR STRTUCTURE) ROLL FORMING MACHINE for Composite Floor Decking Panels

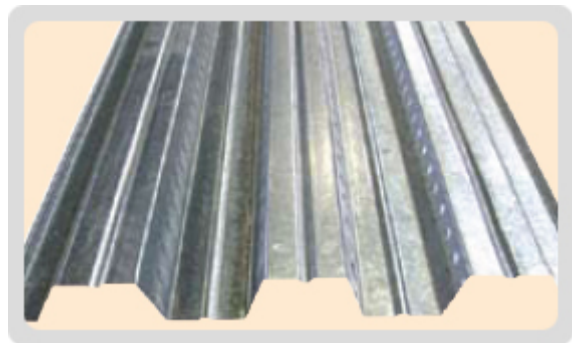
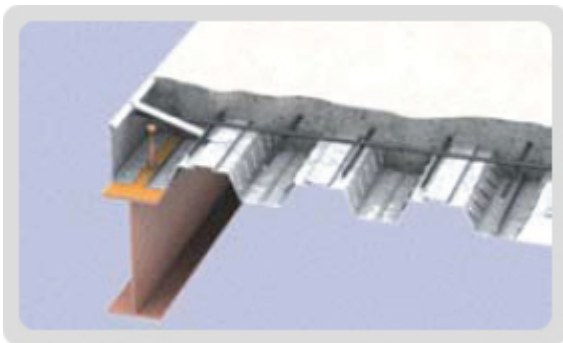

Single Layer (Double Layers) Roofing Corrugated Sheet Roll Forming Machine / Angle Panel Roofing Roll Forming Machine 角型浪板成型機

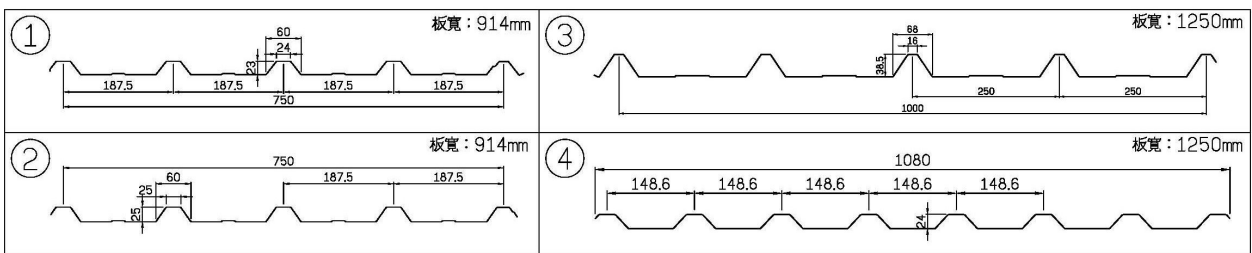

Specification

Unit : mm

Forming Speed(成型速度)	15~20m/min
Roller Shaft Dia. (輪軸直徑)	Ø 75mm
Roller Stations (輪模組數)	18~22 sets
Inverter/Frequency Conversion Motor	25HP

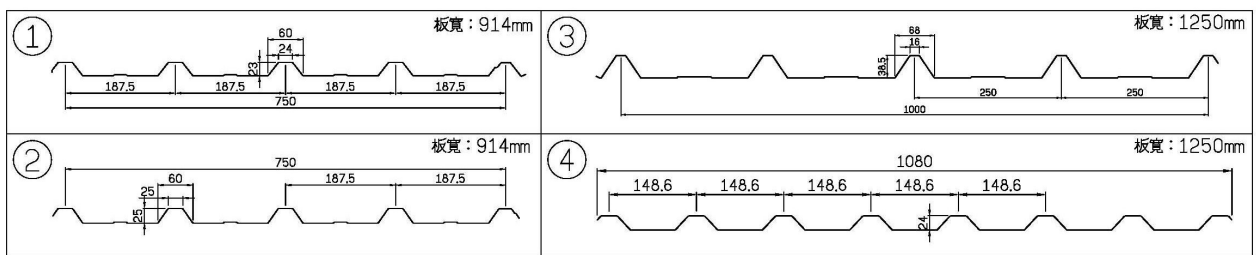

Specification

Unit : mm

Forming Speed(成型速度)	15~20m/min
Roller Shaft Dia. (輪軸直徑)	Ø 75mm
Roller Stations (輪模組數)	18~22 sets
Inverter/Frequency Conversion Motor	25HP

Quincuncial Type Corrugated Single Layer Roofing Corrugated Sheet Roll Forming Machine 梅花型浪板成型機

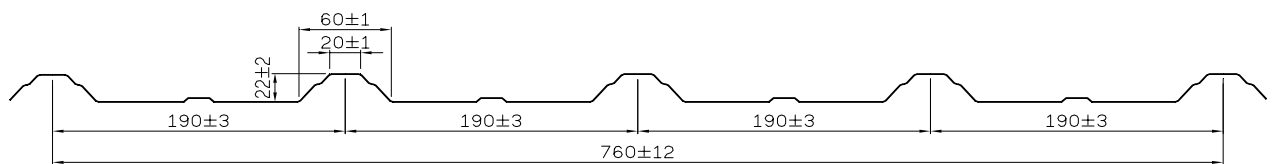

Unit : mm

Specification

Forming Speed(成型速度)	15~20m/min
Roller Shaft Dia. (輪軸直徑)	Ø 75mm
Roller Stations (輪模組數)	18~24 sets
Inverter/Frequency Conversion Motor	25HP



FULLY AUTOMATIC T GRID CEILING “CEILING T-BAR” ROLL FORMING MACHINE for Main T / Cross T / Wall Angle (全自動“天花板龍骨”輥輪成型機)

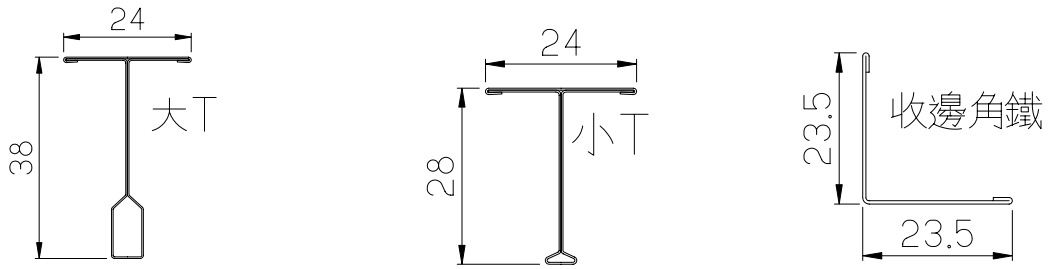

SPECIFICATION (規格)

Unit : mm

Name	Material Thickness 材料厚度	Forming Speed 成型速度	Roller Shaft Dia. 輪軸直徑	Motor Output 動力馬達
Main T	0.3mm	8~12M/min	Ø 40mm	Speed Reducer 5HP+ Inverter
Cross T	0.3mm	6~10M/min	Ø 40mm	Speed Reducer 5HP+ Inverter
Edge Wall Angle	0.5mm	8~12M/min	Ø 40mm	Speed Reducer 3HP+ Inverter



U Channel Steel Roll Forming Machine(槽鋼成型機械)

Specification (規格)

Unit : mm

Material Thickness 材料厚度	Forming Speed 成型速度	Roller Shaft Dia 輪軸直徑	Motor Output 動力馬達
2.0mm , 3.0mm	10~20M/min	Ø70mm	25HP*1

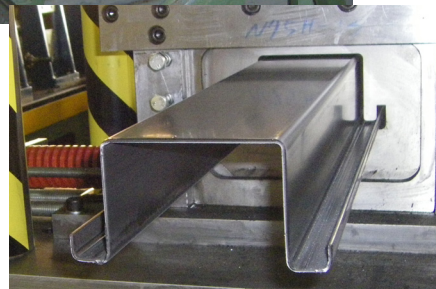

Automatic C Purlin Roll Forming Machine / Partition Beam Roll Forming Machine / Lightweight C-Shape Forming Machine (C 型鋼成型機)

Specification

Unit : mm

A x B x C	Material Thickness 材料厚度	Forming Speed 成型速度	Roller Shaft Dia 輪軸直徑	Motor 動力馬達
75 x 45 x 15	1.6mm~2.6mm	12~20M/min	Ø 60mm	15HP
100 x 50 x 20	1.6mm~2.6mm	12~20M/min	Ø 60mm	20HP
125 x 50 x 20	1.6mm~2.6mm	12~20M/min	Ø 60mm	20HP
150 x 50 x 20	2.0mm~4.0mm	12~20M/min	Ø 70mm	25HP
150 x 65 x 20	2.0mm~4.0mm	12~20M/min	Ø 70mm	25HP
200 x 75 x 20	2.6mm~4.0mm	12~20M/min	Ø 70mm	30HP

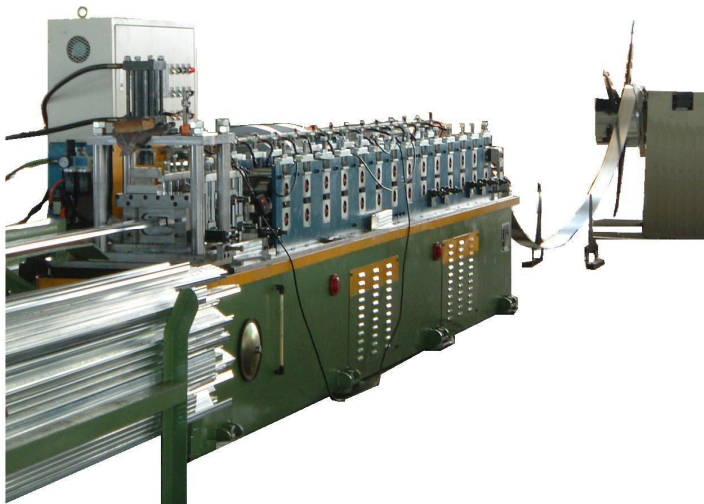
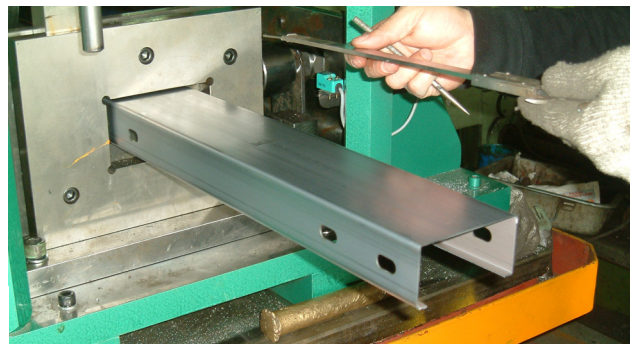
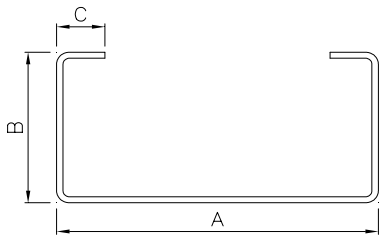

Automatic C Purlin Roll Forming Machine with Hole Punching Machine / C-Shape Forming Machine (C 型鋼成型機-線上沖孔)

Material Thickness 材料厚度	Forming Speed 成型速度	Roller Shaft Dia 輪軸直徑	Motor Output 動力馬達
3.0mm	5~15M/min	Ø 70mm	15HP*2

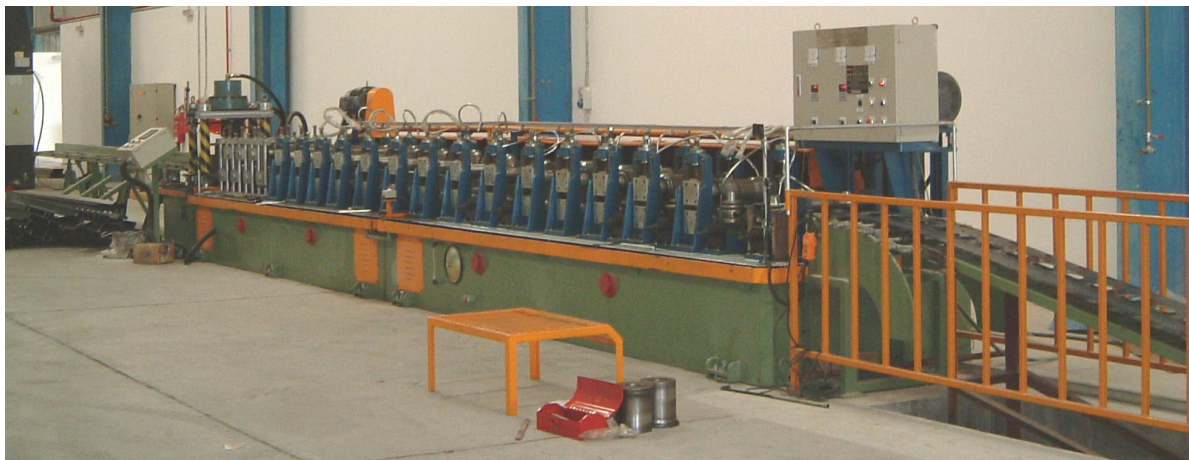

Roof Channel Steel Roll Forming Machine(屋頂槽鋼成型機)

SPECIFICATION

Forming Speed 成型速度	15~20m/min
Roller Shaft Dia 輪軸直徑	Ø 50
Transmission Mode 傳動方式	Chain and Gear
Inverter/Frequency Conversion Motor	20HP



Unit : mm

Model	A	B	C	D	E
CF-RC01	30	50	80	40	5
CF-RC02	40	50	82	40	5
CF-RC03	40	50	82	50	5

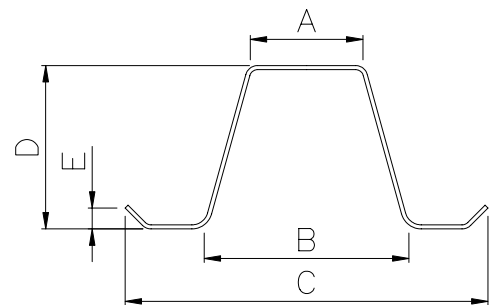

名稱：異型管成型機 SPECIAL DESIGN PROFILE ROLL FORMING MACHINE



AIR FILTER FRAME ROLL FORMING MACHINE / AIR FILTER FRAME ASSEMBLY MACHINE

C profile

壓條形體圖

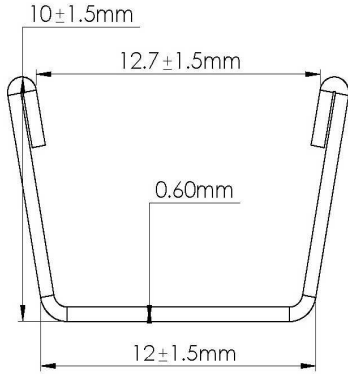

材料寬度約 35mm
厚度 0.6mm
300mm=50.05公克

Raw Material Coil Width: about 35mm
Thickness: 0.6mm
300mm Length= 50.05g

Inner frame

內框形體圖

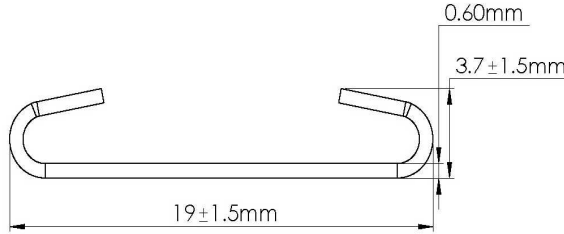

材料寬度約 29mm
厚度 0.6mm
300mm=41.37公克

Raw Material Coil Width: about 29mm
Thickness: 0.6mm
300mm Length= 41.37g

Outer frame

外框形體圖

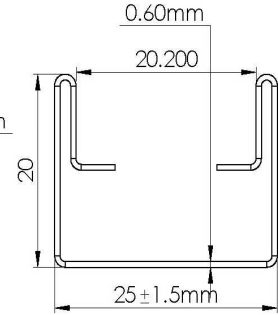

材料寬度約 91.9mm
厚度 0.6mm
300mm=129.37公克

Raw Material Coil Width: about 91.9mm
Thickness: 0.6mm
300mm Length= 129.37g



C Profile and Inner frame
Assembly Drawing

壓條與內框裝配圖

Reserve 1.6mm gap for left side and right side
to put the filter media(bag)

左右預留1.6mm方便裝布

壓條
C Profile

Inner Frame 內框

Reserve space of 1.9mm between inner frame and inner frame
內框之間已預留1.9mm

Outer frame and Inner frame
Assembly Drawing

外框與內框裝配圖

內框
inner frame

左右皆有縫隙(0.6mm)方便安裝
0.6mm space in left side
and right side to
assembly the frame easily

外框
outer frame

Automobiles Bumper Roll Forming Machine

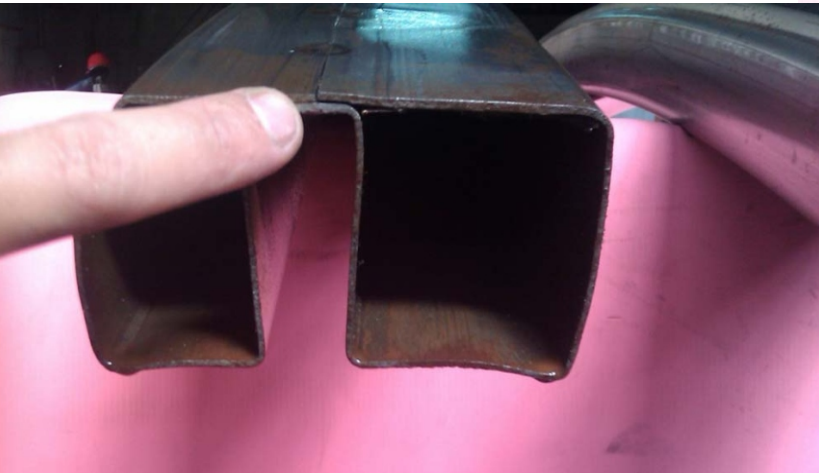

Horizontal Flat Steel / Flat Iron Polishing Machine

材料厚度 Material Thickness	規格寬度 Product Width	拋光速度 Polishing Speed
3mm~8mm	25 mm~120mm	10m/min~15m/min

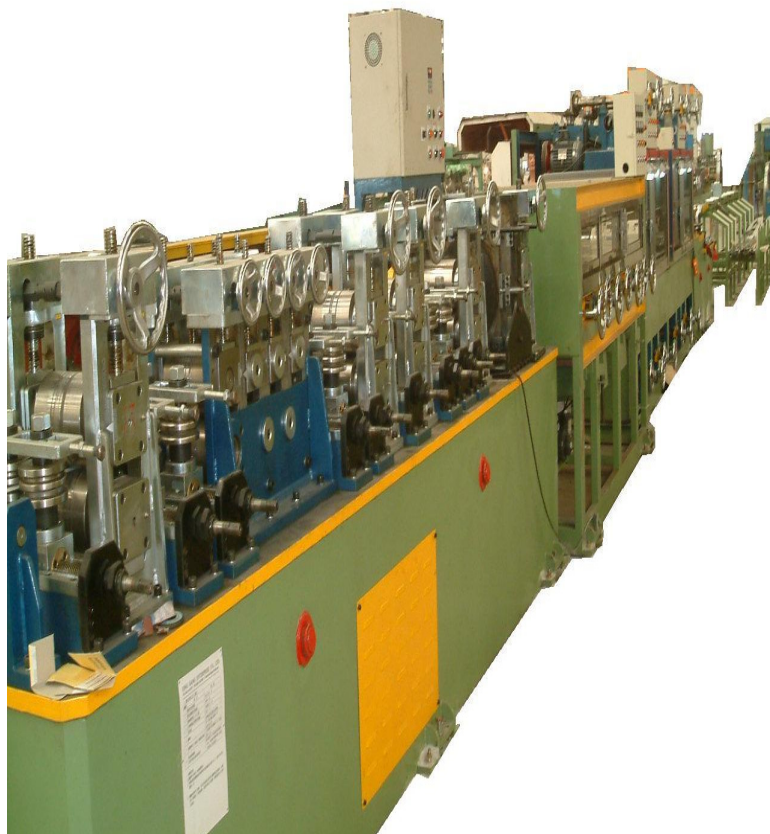

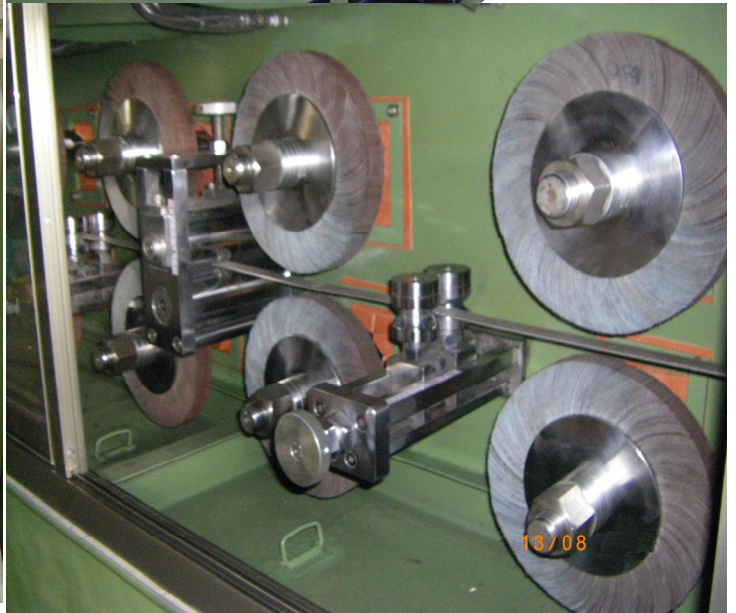

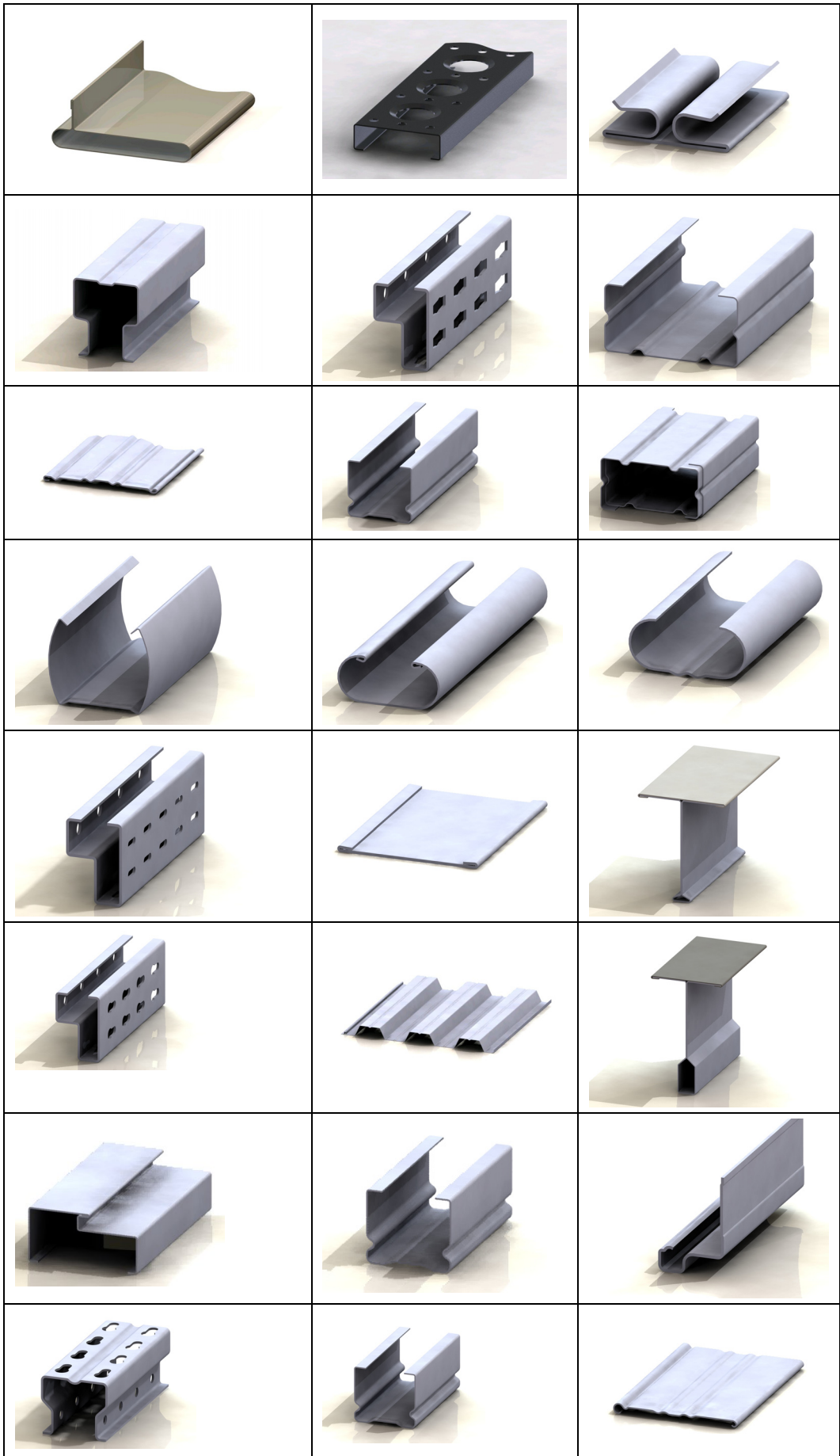

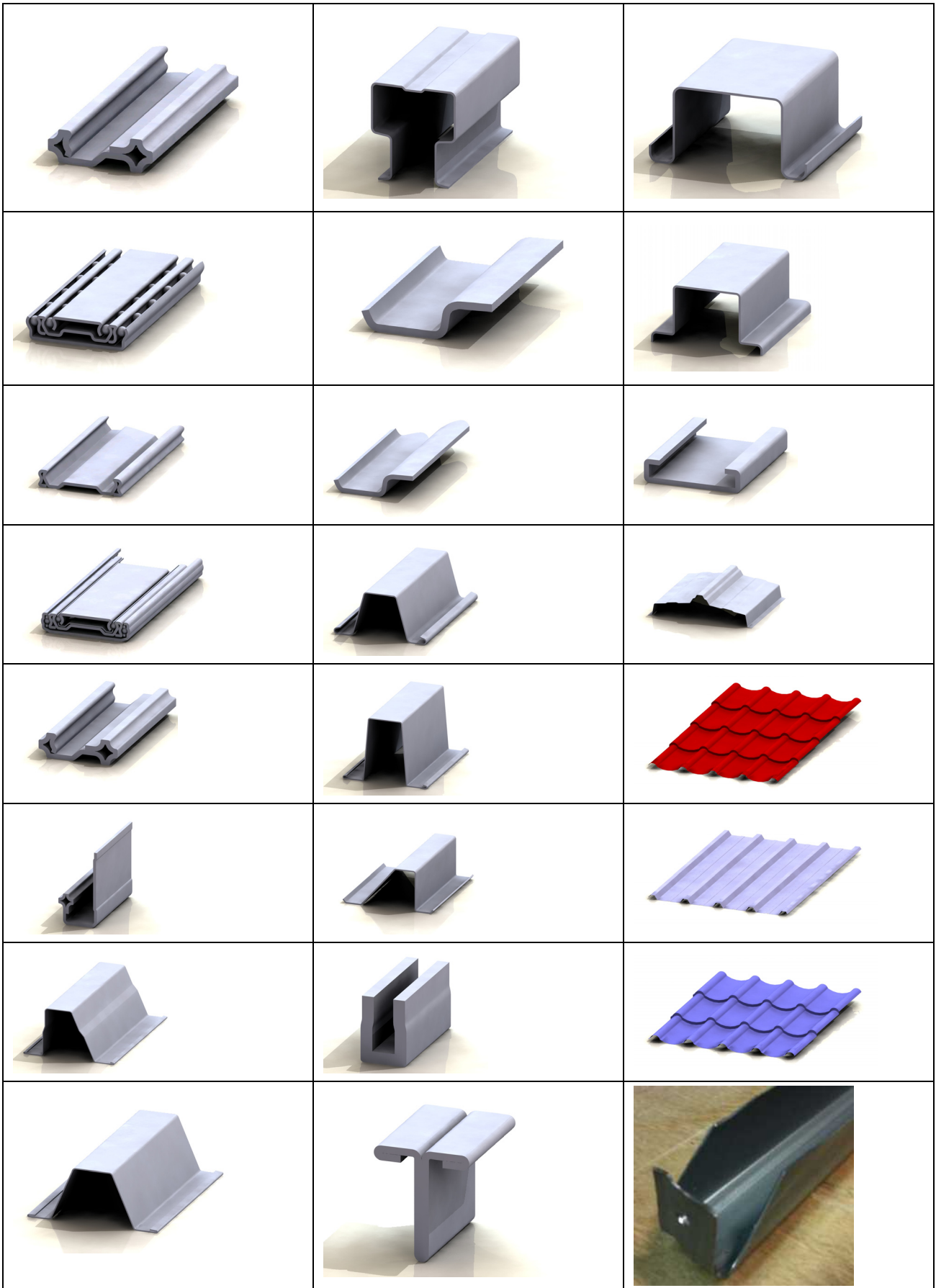

Single Layer (Double Layers) Roofing Corrugated Sheet Roll Forming Machine



SHEET THICKNESS (鐵板厚度)	0.3~ 0.8mm
FORMING SPEED (成型速度)	15~ 20m/min
ROLLER SHAFT DIA. (輪模軸徑)	Ø75mm
MOTOR OUTPUT (動力馬達)	10 ~20hp
SINGLE HEAD UNCOILER (單頭放料架載重)	5~8 Ton

